



15F2916

# 737 / 100-900 Towbar



## Building Quality Ground Support Products Since 1961

- 8" x 15' high strength aluminum tube
- Safety lock system to avoid separation from aircraft
- Fully retractable hydraulic running gear for adjustable height
- Durable powder coated paint
- Quality shear bolts for aircraft protection
- Extra set of shear bolts included
- Solid tires
- Options:
  - Foam filled tires
  - Pneumatic tires
  - Shock mounted lunette

# CLYDE

Clyde Machines  
P.O. Box 194  
1150 Hwy 55 N.  
Glenwood, MN 56334 USA  
(320) 634-4504  
(320) 634-4506 Fax

[www.clydemachines.com](http://www.clydemachines.com)

# 15F2916

## 737 / 100-900 Towbar

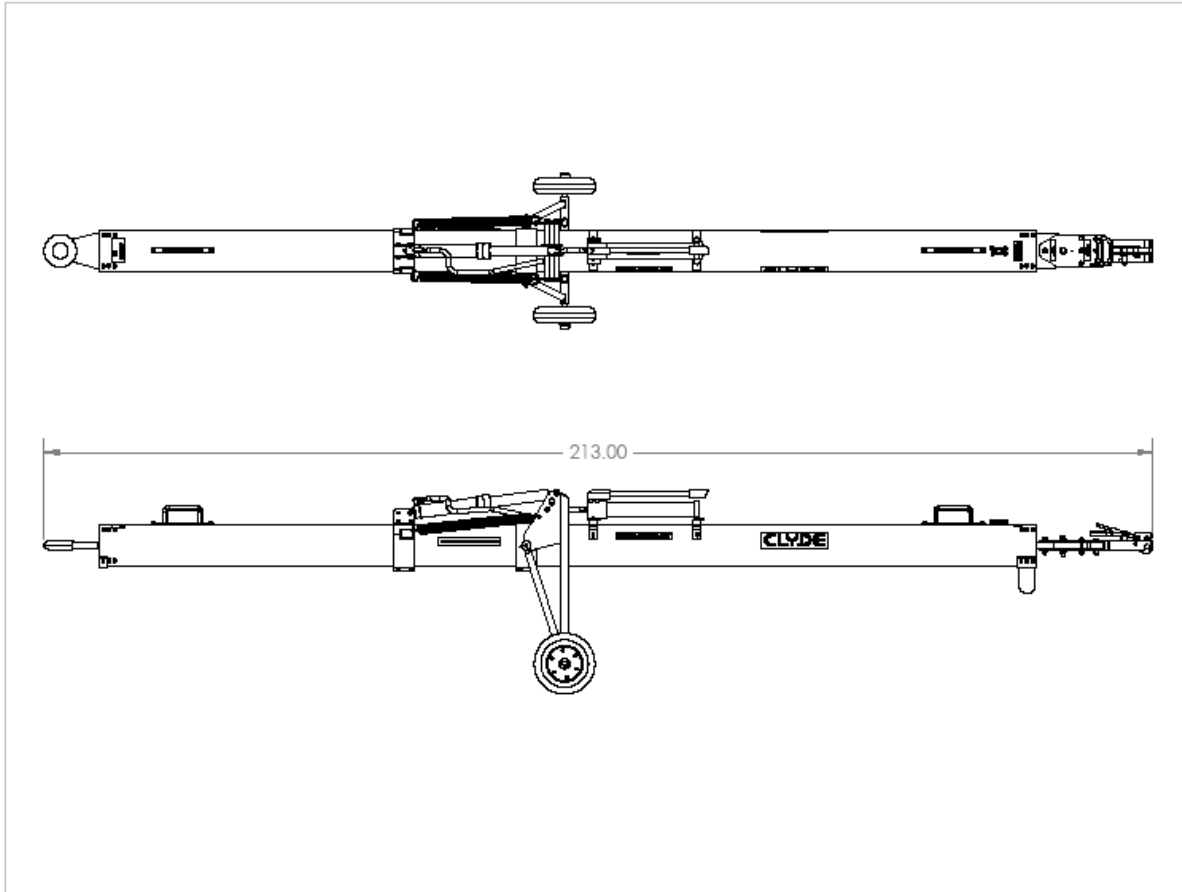

### Shipping Information

- Shipping weight:
  - 325 lbs.
- Shipping dimensions:
  - Length - 205"
  - Width - 25"
  - Height - 25"
- Crated weight:
  - 730 lbs.
- Crated dimensions:
  - Length - 217"
  - Width - 26"
  - Height - 27"

# CLYDE

Clyde Machines  
P.O. Box 194  
1150 Hwy 55 N.  
Glenwood, MN 56334 USA  
(320) 634-4504  
(320) 634-4506 Fax

[www.clydemachines.com](http://www.clydemachines.com)